

---

# DIgSILENT Pacific User Conference

## Melbourne 2011

---

### Verified and Validated Protection Models



**Peter Willis**

DIgSILENT Pacific

**Randy Supangat**

DIgSILENT Pacific

**Nguyen Dong Hai Le**

DIgSILENT Pacific

#### **ABSTRACT**

DIgSILENT has a uniquely comprehensive protection modelling offer through *PowerFactory* and *StationWare* products. In *PowerFactory*, relays are modelled as detailed secondary controllers responding to system conditions in both steady state and dynamic simulations. In *StationWare* settings are comprehensively stored and managed through a lifecycle process. *StationWare* can deal with numerous vendors' proprietary setting files through import and export filters. Finally *PowerFactory* and *StationWare* can exchange information via DPL import/export scripts allowing protection engineers to efficiently manage large volume of data and avoid associated data entry errors.

With this capability however there is emphasis on having precise models that reflects actual functionality for specific relay models down to hardware and firmware codes.

The paper explores the process of developing and licensing DIgSILENT *Verified* and *Validated* protection models, being matched pairs for *PowerFactory* & *StationWare* complete with manuals, benchmarking tests and ongoing support.

(Note: Only the term *Verified Model* has been applied throughout this paper. A *Validated Model* is a *Verified Model* that has been tested against a physical relay and secondary injected to provide further certainty the model reflects the expected relay function).

## INTRODUCTION

For more than a decade, DIgSILENT *PowerFactory* has provided a uniquely powerful ability to model protection relays. Rather than just displaying time overcurrent curves and R-X characteristics on a graph together with calculation results, *PowerFactory* aimed to model relays as detailed secondary systems that monitored primary circuits. Furthermore, instead of hard-coding these protection models, *PowerFactory* was enabled with functionality for users to build protection relays up from a library of discrete protection stages in a similar way that relay manufacturers apply to describe their product's functionalities to protection engineers.

Throughout the 1990's numerical relays continued to rapidly innovate such that the number of discrete settings quickly exceeded the limits of traditional settings management systems. Before long, relays became multifunction devices that could only be practically configured by computers and had associated settings from several hundred to several thousand. DIgSILENT *StationWare* was developed to manage these settings and also target the proprietary setting file formats to enable efficient translation of data. More importantly for the protection engineer, *StationWare* offered a settings repository for *PowerFactory* to access via DPL Scripts.

Understanding relay behaviour for the purposes of device modelling is a complex task and even DIgSILENT customers with both *PowerFactory* and protection relay expertise may prefer the option of DIgSILENT developing the required models. For industrial customers however, the protection expertise is rare to find in-house and external consultants are often employed to handle protection grading studies. In these circumstances, the required models are invariably expected as always being available in advance and as part of the software library.

DIgSILENT provides 'Standard' models free of charge with *PowerFactory* and *StationWare* and these cover approximately 200 popular relays. Customers are free to adapt the model for their specific requirements and to reflect the behaviour of specific variants.

## THE NEED FOR VERIFIED MODELS

Following some large industrial modelling projects DIgSILENT Pacific decided to offer a service whereby any relays required by a customer can be provided under a license basis. By licensing the model the customer does not face the full development costs and the model remains available to license to other customers.

DIgSILENT found that customers often request a relay model, without understanding the impact of the differences in functionality and settings between the many hardware and firmware variants available for that particular relay.

In order to provide a relay model that confines parameters only to the settings available on a specific relay, Verified Models were developed. This avoids the situation whereby the protection engineer may inadvertently rely upon availability of functions or settings, that are known to be generally available within a protection relay family, but not specifically available to the actual physical relays that invariably have specific options and functions.

Protection engineering is truly as case of 'The Devil is in the detail' and this will be illustrated with two very simple cases of device modelling:

- GEC CDG relay
- Schneider Masterpact ACB

### ***GEC CDG Relay***

The CDG is an induction disc inverse time relay and was one of the most common relays used in Australia and throughout Commonwealth countries having been manufactured since the 1950's. Initially, made by English Electric a series of company takeovers and mergers have seen the CDG model also badged as GEC, GEC-Alsthom, Alstom and Areva T&D. In 2010, Areva T&D was sold to Alstom and Schneider and the CDG story will presumably continue.

The CDG relay models have combinations of individual and multiple induction disc units with trip indicator and optional instantaneous element and are generally referred to as **CDGxy** whereby,

- **x** refers to both the number of disc elements or presence of instantaneous elements in the case:
  - 1-Single Element Inverse Time
  - 2-Single Element Inverse Time with Instantaneous
  - 2-Dual Element Inverse Time
  - 3-Triple Element Inverse Time
  - 5-Triple Element Inverse Time with 2 Instantaneous Elements
  - 6-Triple Element Inverse Time with 3 Instantaneous Elements
  
- **y** is the curve type :
  - 1- Inverse Time (of which there are 1.3s and 3s curve variants within)
  - 2- Long Time Delay
  - 3- Very Inverse Time
  - 4- Extremely Inverse Time
  - 6- Inverse Time (with isolated outputs)

Assuming all individual elements in a case are the same, these choices alone permit 36 variants of the CDG family. With consideration that the triple elements cases can be either 3PH or 2PH+E, this extends to 54 variants with each having unique differences in both their *PowerFactory* and *StationWare* models

This however is only the beginning of the possibilities. For any Inverse Time element, CDG were available with 9 difference 'Preferred' taps and a further 7 'Standard' taps. Restricting outcomes to normal practice that within any given relay case, Phase elements always have the same taps; the possible outcomes extend to an estimated 9,516.

Adding to this, is the fact that over the years of having successive parent companies and their subsidiaries handling assembly locally (as occurred in Australia), there evolved an unknown number of model naming conventions.

It would be an unreasonable burden for DIGSILENT to prepare ~10,000 variants of the CDG relay modelled in the PowerFactory library ready for use given the vast majority of the combinations may have never been built.

Even if that was achieved however when an actual relay model number was presented, it could not be readily correlated to the required model due to decades of different model codes.

This illustrated by a just a small range of existing models numbers that follow below.

- CDG11AF5C
- CDG11AML21AF4G
- CDG31EG162A
- CDG66AML23FF608G

## Verified and Validated Protection Models

In the event that a request comes to DigSILENT for a relay model to suit CDG61EG/RP166D5, the process would be to examine the relay to determine what taps ranges apply. Figure 1 illustrates this model where it is clear the relay is a 3 element horizontal CDG configured 2PH +E.

The Phase Elements have 3sec Inverse Time (Standard) curves with standard phase taps of 2.5A-10A in 1.25A increments. The Earth Element is also 3sec Standard Inverse curve with standards taps 0.5-2A in 0.25A increments.



Red Phase Element

Earth Element

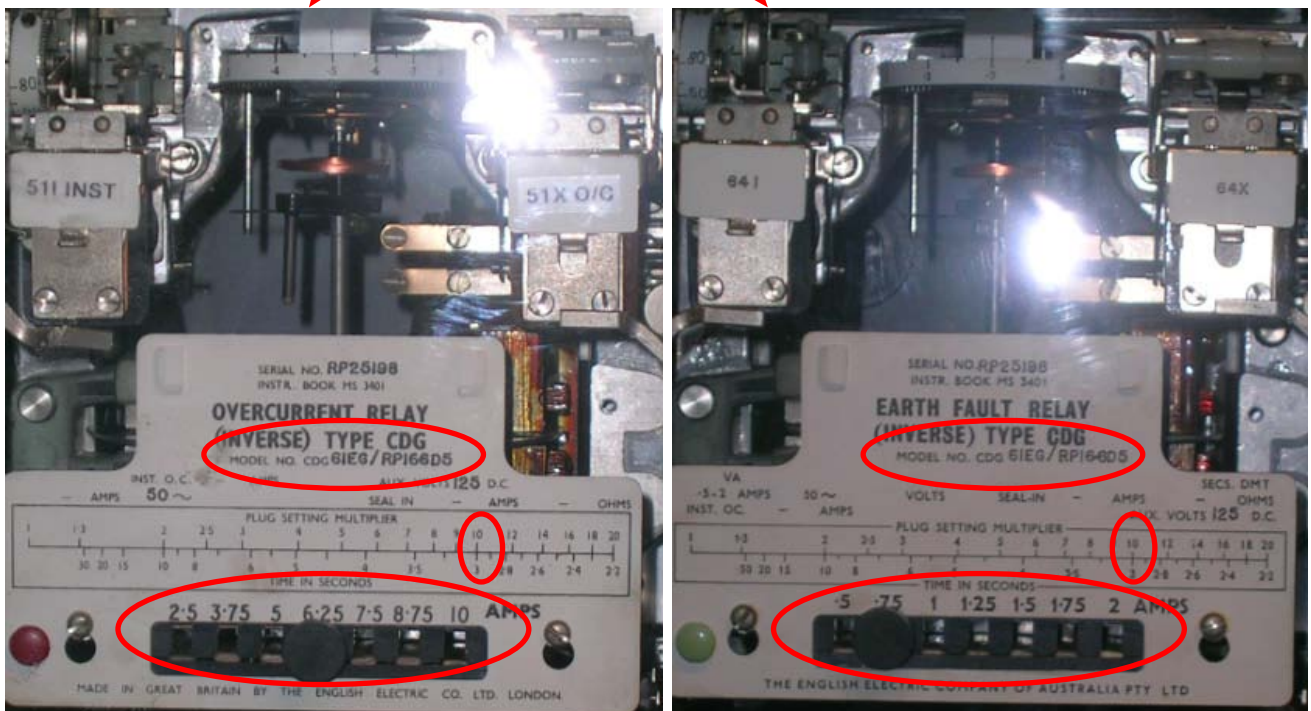

**Figure 1 – Photos of English Electric Co. Relay Model code CDG61EG/RP166D5**

It is noteworthy that the nomogram on faceplate is the only indication on a CDG relay of whether the 1.3sec or 3sec curve applies. Clearly, has significant impact on protection response modelling.

The block diagrams of the other various CDG models are illustrated in Figures 2, 3 and 4 over page.

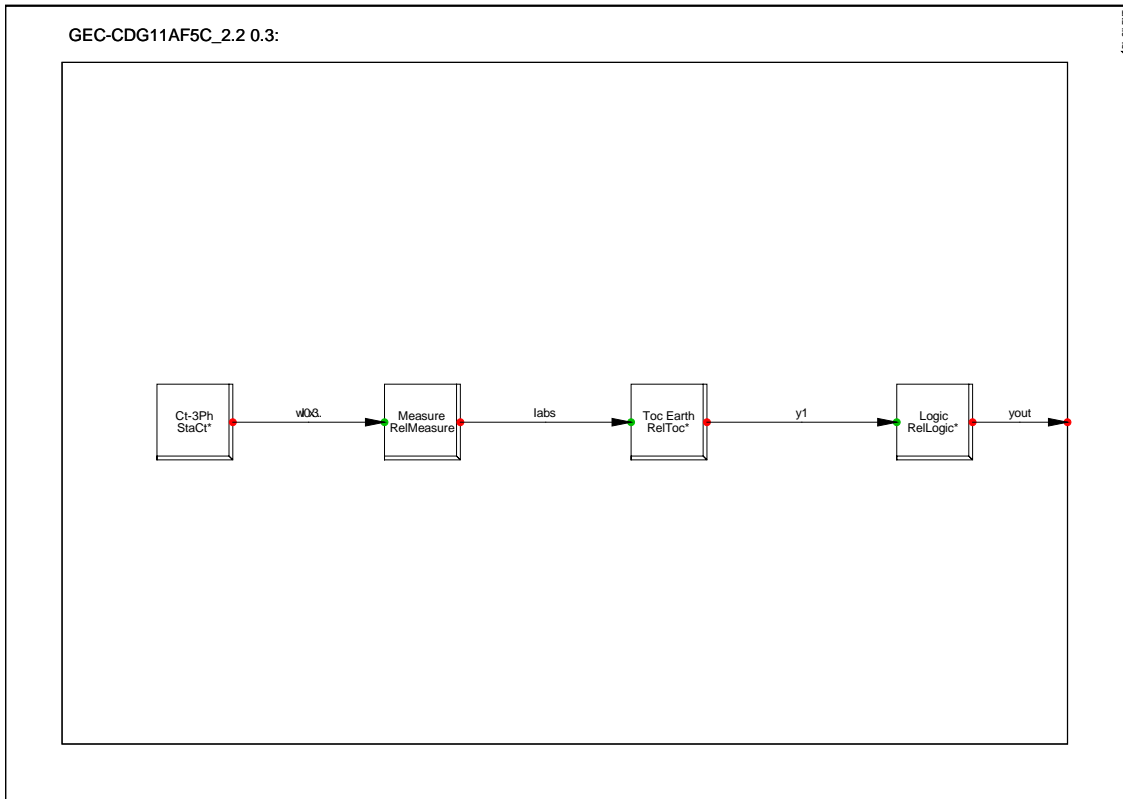

Figure 2 – PowerFactory Block Diagram for GEC-CDG11AF5C Relay

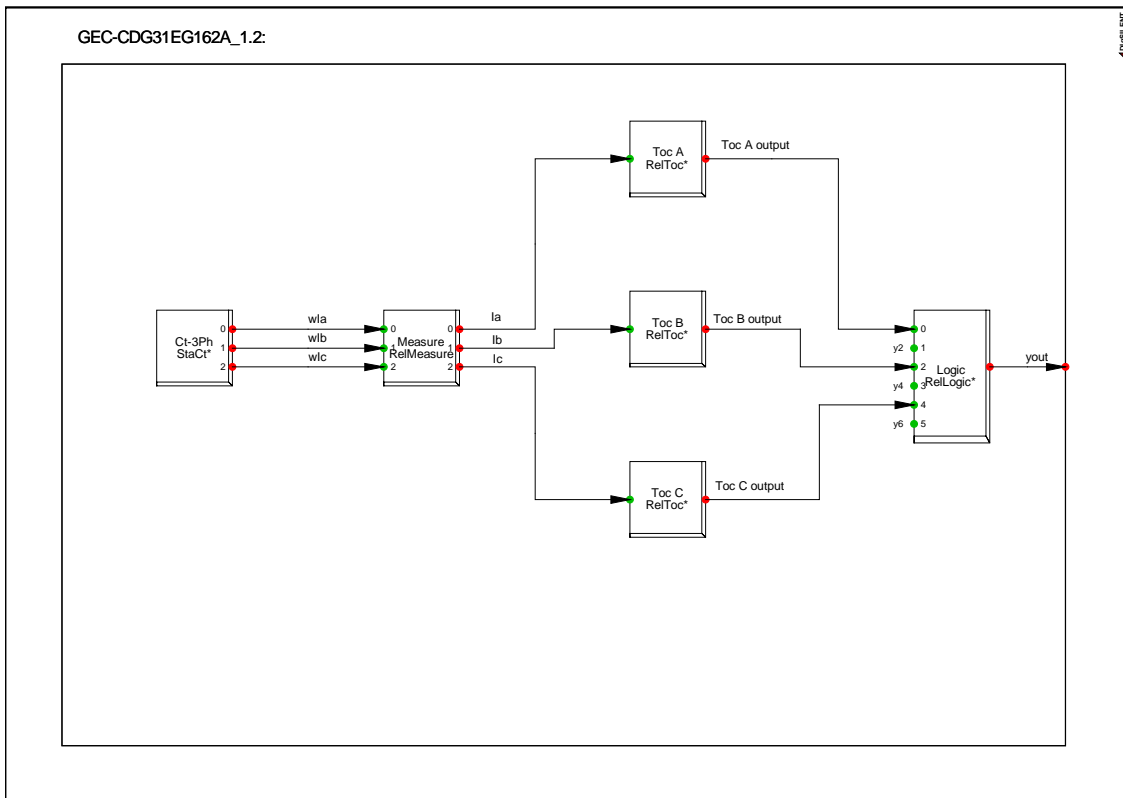

Figure 3 – PowerFactory Block Diagram for GEC-CDG31EG162A Relay

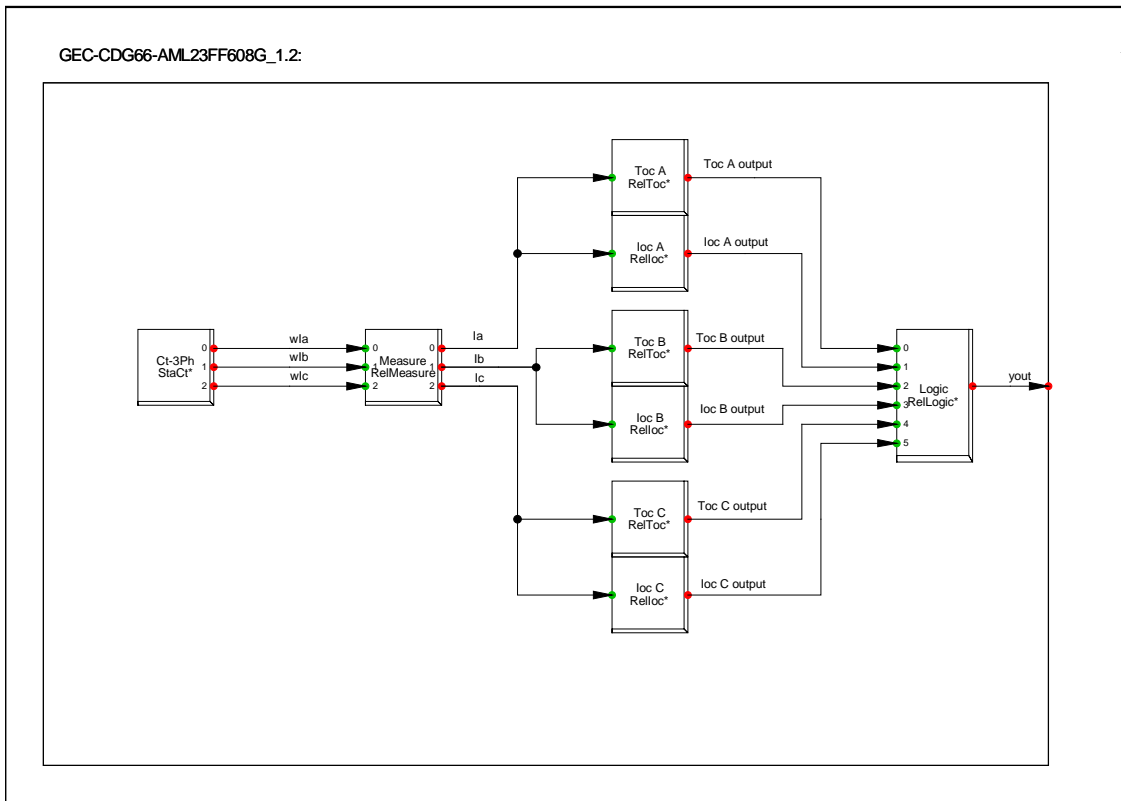

Figure 4 – PowerFactory Block Diagram for GEC-CDG66-AML23FF608G Relay

On this basis of the forgoing, it is demonstrated that when someone requests a 'CDG' model or perhaps a 'CDG 31' this does not narrow down the detail sufficiently to prepare a protection model.

### *Schneider Masterpact LV Air Circuit Breaker*

The Masterpact ACB is a model of LV circuit breaker that has been available for the last 20 years. Originally a Merlin Gerin product from within the Schneider Group, it was also branded as Square-D in the USA. Schneider has since dropped the Merlin Gerin branding from all their products but this history would not be obvious to recent engineers entering the workplace.

Aside from changes in branding, the first complication with modelling the latest Masterpact breaker is that it comes in many different ratings across three frames and 2 families (NW and NT) whereby each is available either a 3-pole or 4-pole model as follows.

- 630A
- 800A
- 1000A
- 1250A
- 1600A
- 2000A
- 2500A
- 3200A
- 4000A
- 5000A
- 6300A

The second complication is that for each frame, there are generally 4 models types (N1, H1, H2, L1) types corresponding to the ACB maximum fault current rating and hence, impacting on the instantaneous setting ranges of trip units. This equates to 96 different ACB models just for the second generation (NW & NT) Masterpact.

The third complication is that the term 'Masterpact' applies to the ACB but several different trips units can be embedded installed in it. In the first generation of the Masterpact, there were 6 models of STR-type trip units available:

- STR08I
- STR28D
- STR38S
- STR38U
- STR58U
- STR68U

In the STR38 and STR58 models, ground fault element was available as an option but this did not affect the trip unit model code displayed on the faceplate.

In the second generation of the Masterpact, the STR units have been replaced with 10 different Micrologic trip units:

- Micrologic 2.0A
- Micrologic 5.0A, 5.0P or 5.0H
- Micrologic 6.0A, 6.0P or 6.0H
- Micrologic 7.0A, 6.0P or 7.0H

The 'H' suffix of the Micrologic trip units relates to harmonic measurement and has no modelling or settings impact, so that leaves 7 variants.

On the basis of the ACB and trip unit combination, the latest generation of Masterpacts therefore would require 686 different models to cover the possible variants. An example of one physical relay is provided below in figure 6.



Figure 5 – Merlin Gerin Masterpact ACB 1600A H1 3-pole fitted with STR 58U trip unit no GF

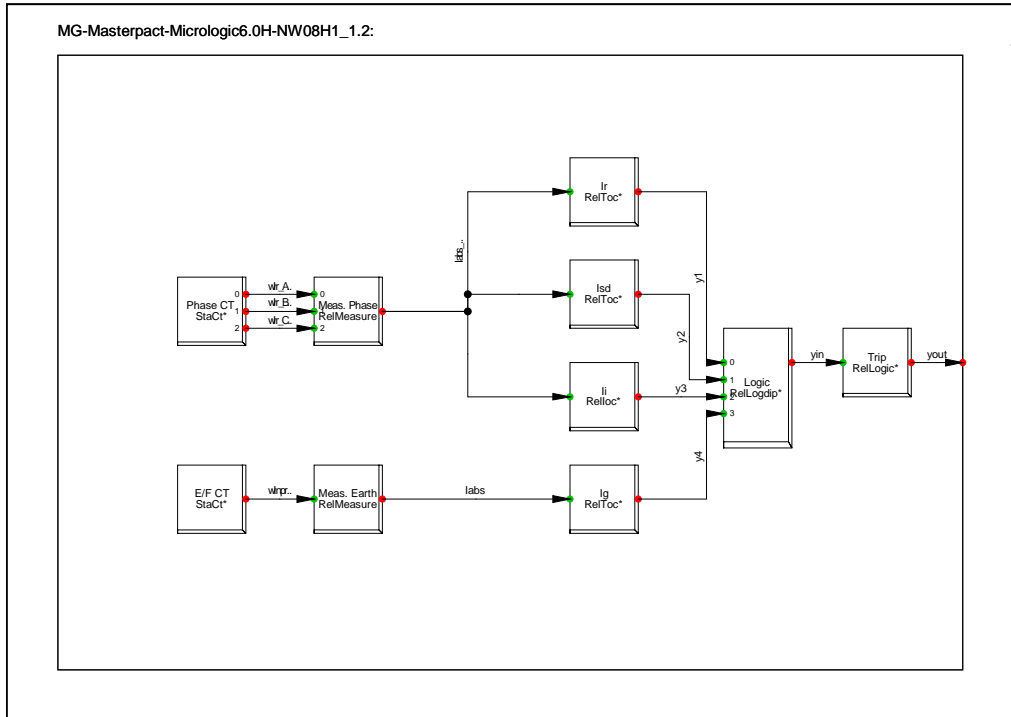

Figure 6 – PowerFactory Block Diagram for Masterpact NW 800A H1 ACB with Micrologic 6.0A Trip Unit

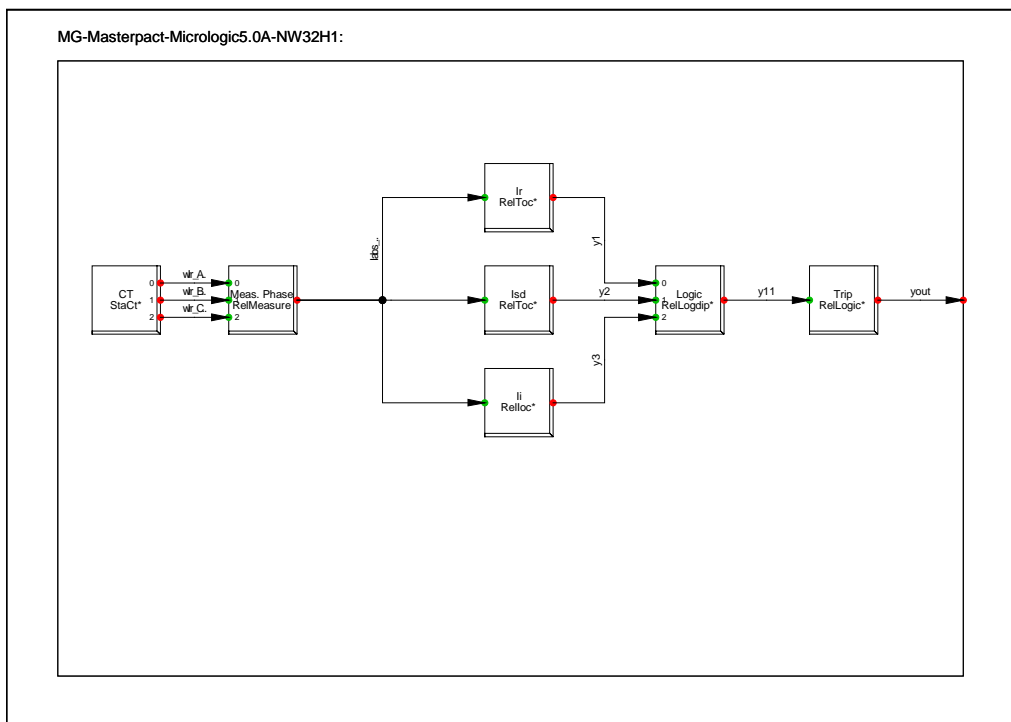

Figure 7 – PowerFactory Block Diagram for Masterpact NW 3200A H1 ACB with Micrologic 5.0A Trip Unit



## MODELLING NUMERICAL RELAYS

Having introduced two simple relay families, the challenges of numerical relay modelling will now be explained. These devices can be extremely complex because in general terms, the feature set of a relay is limited by microprocessor capacity and I/O.

For device modelling, the preferred approach taken is to include all protection stages that are supported and this requires very large block diagrams as illustrated in Figure 8 below. When this gets unmanageable, block diagrams can be embedded within block diagrams.

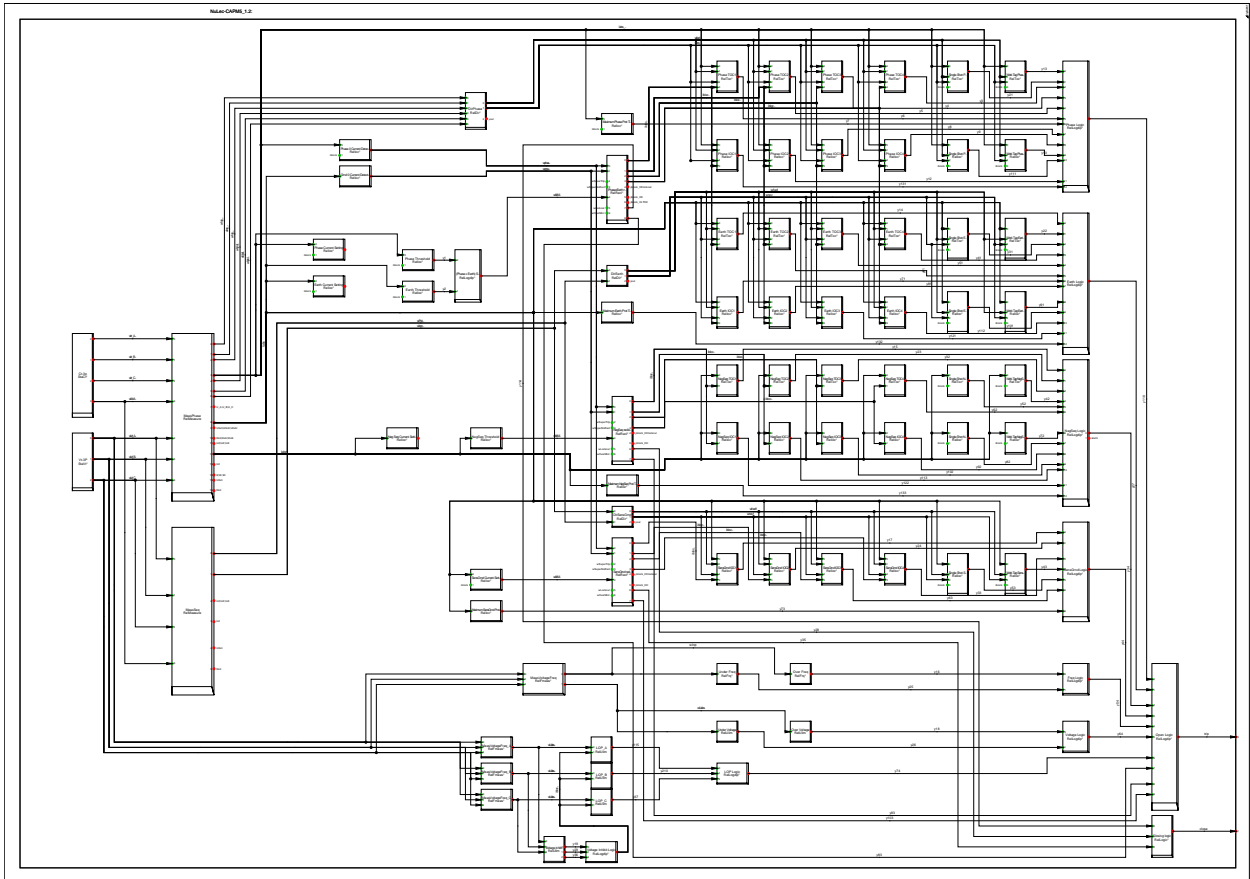

**Figure 8- Schneider Nulec N-Series Recloser CAP5M V28 Controller**

Within each protection stages, there are unique parameters that enable the stage, store settings and control the way PowerFactory simulates the relays. These PowerFactory parameters are derived from and correlate to actual settings used by the relay and can be retrieved from StationWare. It is important however that the PowerFactory model only reflects the functionality available in the targeted protection relay which can vary across firmware releases due to enhancements, bugfixes and control modes. This equally applies to the import/export scripts between PowerFactory and StationWare.

There are no industry standards driving this process and each relay manufacturer applies all their innovative and skill to position their product strongly in international the market. The impact of multiple language support, UTC time format etc all presents difficult challenges in settings modelling and settings management for DIGSILENT.

## STATIONWARE IMPORT FILTERS

An import feature of StationWare is the capability to import settings by converting or filtering a relay vendor's proprietary setting file format. This is achieved by *Import Filters* which in some cases also includes settings export capabilities.

These filters are bespoke extensions of StationWare that are separately licensed. In some cases, an *Import Filter* needs only target the vendor's settings software platform and therein support huge number of devices (such as Siemens DIGSI 4). In other cases, settings files must be associated with a vendor's own model and/or firmware definition file in order to interpret the data fields correctly. In extreme cases a filter might be hard coded to target one device and firmware combination.

Each required *Import Filter* is licensed to *StationWare* customers by DIGSILENT GmbH and is handled separately to Verified Models licensing.

For Verified models of numerical relays, the DPL script for settings exchange between PowerFactory and StationWare is coded to target StationWare parameters constructed by *Import Filters*.

## OBTAINING VERIFIED MODELS

Verified models are developed upon request from DIGSILENT customers and provided for a license fee.

The principles underlining the supply of Verified Models are:

- 1) The customer requires a protection relay model but does not wish to develop a model.
- 2) DIGSILENT are prepared to develop detailed models of relays that are required by customer based on the assumptions other customers will require them also over time and costs are recovered.
- 3) The license cost does not depend on whether the relay still needs to be developed or is already available. Licenses costs are typically 10-40% of development costs.
- 4) All models come with user documentation and a test report.
- 5) Models are covered under conventional DIGSILENT maintenance and support contracts.

## DEVELOPMENT PROCESS

Both hard assets (i.e. Power Networks) and soft assets (Power Network Models) must be maintained over their lifetime to get the intended benefits. The expectations for the Verified Model should be identical to the actual relay such it will continues to work despite successive upgrades of *PowerFactory* and *StationWare* over the long term.

To achieve this, relay models must go through stages of *development*, *testing*, *production* and *release* (as figure 9) but return back to *development* for any bug-fixes, enhancements or upgrades as *PowerFactory* and *StationWare* move forward.



Figure 9- The stages of model development

DIgSILENT license the individual models to those customers who require them and provide support and maintenance under the existing contracts structures.

The development process is typically separated such that a Protection Engineer builds the model and a separate Test Engineer checks the performance and completes a test report (refer Figure 10 below). This detailed modelling and checking allows a Project Engineer on the client side to use the model in studies knowing the simulation results reported by the released model can be trusted.

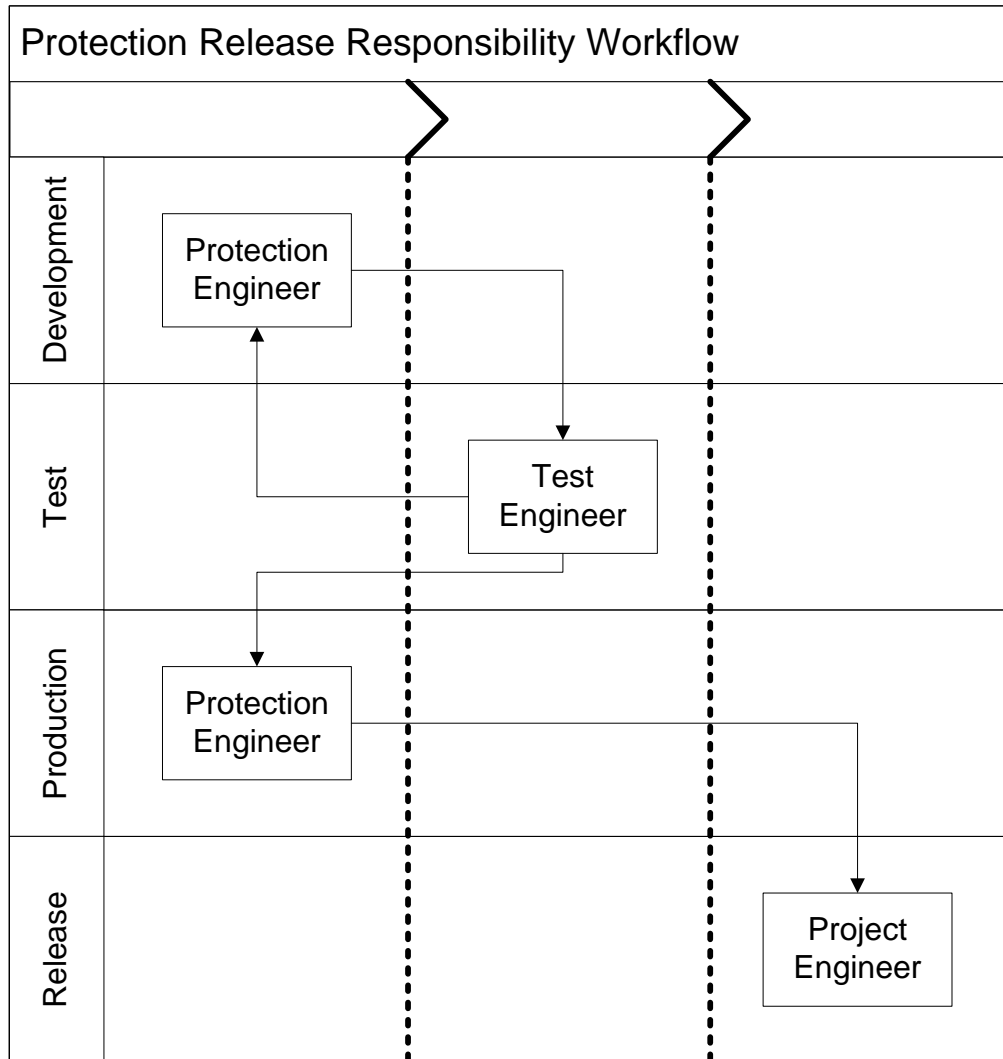

Figure 10- Naming of release models issues to customers

**LICENSING PROCESS AND MODEL RELEASE**

The release of the model is accompanied by a licensing process whereby production models are assigned to a customer and a unique code is generated for each model. The licensing tools then exports models into files than can be transferred to the customer together with licensing paperwork.

Whenever files are released to customers a detailed naming convention is applied as shown in figure 11 below.

## Verified and Validated Protection Models

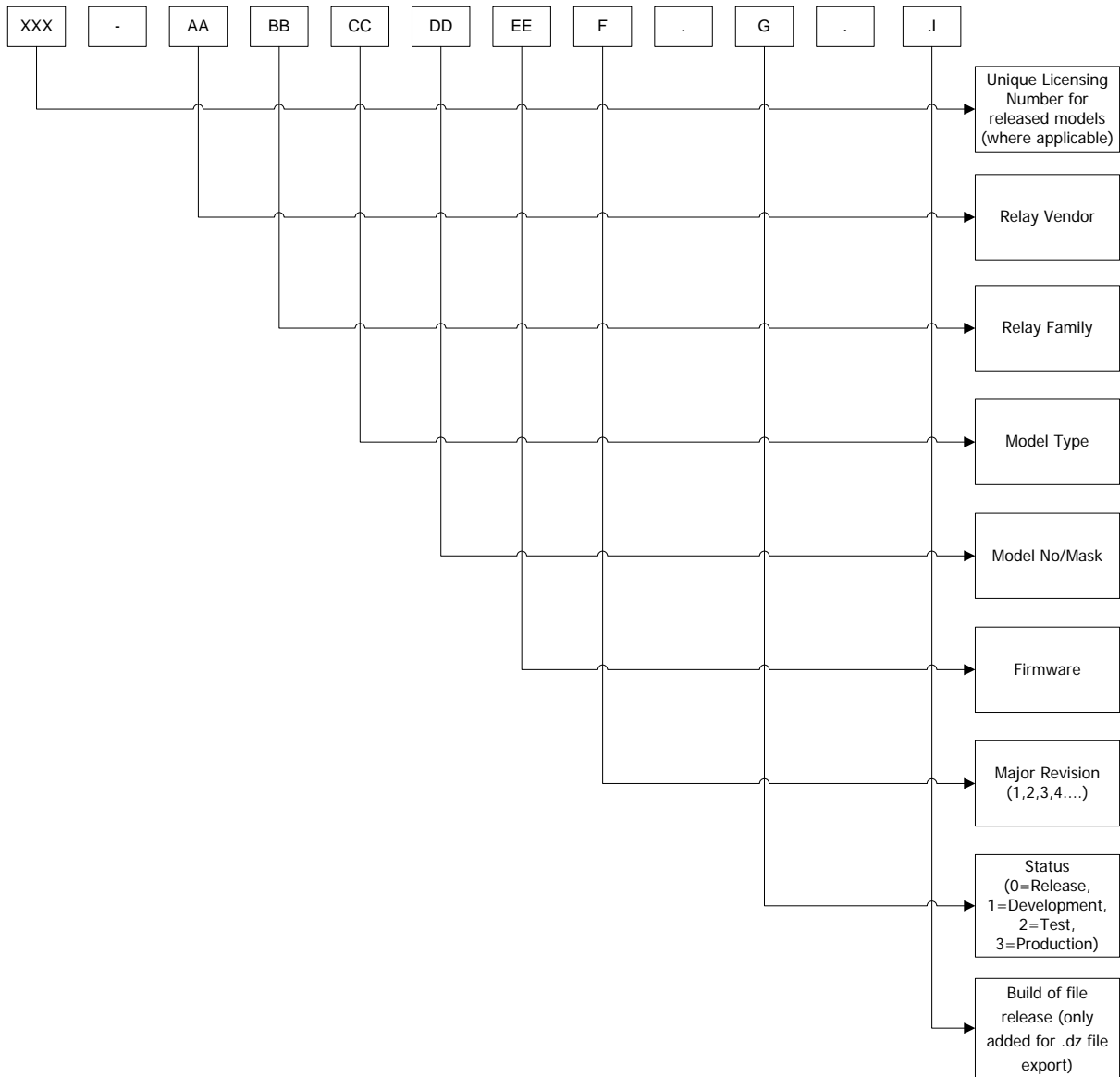

**Figure 11- Naming of release models issues to customers**

The licensing paperwork identifies all the supplied model variants that have been issued including support periods and licensing costs.

## DOCUMENTATION

Every Verified model targets a specific relay model and where applicable, firmware version. In order for the user to use the Verified model, a manual or Protection Release Document is provided for each and every model covering:

- An description of the relay and what functions have been modelled.
- Any user instructions about special limitations or settings combination that must be handled manually in PowerFactory.
- StationWare group, chapter and parameter definitions.
- PowerFactory to StationWare parameter mappings for data exchange.



Rev	By	Checked	Date	Description
1	S. Cho	M. Edger	10/05/2010	Draft
2	P. Willis	P. Willis	30/01/2011	Revised

**DIGSILENT GmbH**  
 Heinrich-Hertz-Strasse 9  
 D-72810 Comaringen  
 Tel.: +49 7072 9168 - 0  
 Fax: +49 7072 9168 - 88  
 http://www.digsilent.de  
 e-mail: mail@digsilent.de

**Title of Document**

Published by

**DIGSILENT Perth**

DIGSILENT Pacific, Australia  
 Suite 11, 2nd Floor 189 St  
 George's Tce Perth WA  
 Tel: + 61 (0)8 9485 1886  
 Fax + 61 (0)8 9485 1887  
 http://www.digsilent.com.au  
 e-mail: info@digsilent.com.au

**DIGSILENT Melbourne**

Suite 8, 437 St Kilda Rd  
 Melbourne, 3004, Vic  
 Tel + 61 3 9820 2320  
 Fax +61 3 9820 2503

Copyright 2010. All rights reserved. Unauthorised copying or publishing of this or any part of this document is prohibited.

**Document ID**

**Version Date**

**10.05.2010**

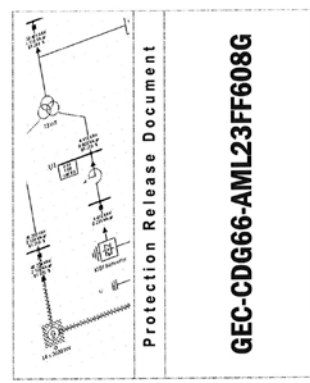

GEC-CDG66-AML23FF608G  
 02071110



## Table of Contents

<b>1 Introduction</b> .....	<b>4</b>
<b>2 Protection Relay</b> .....	<b>5</b>
2.1 <i>PowerFactory</i> Protection Functionality.....	5
2.2 <i>StationWare</i> Settings Template.....	7
2.3 Interface between <i>PowerFactory</i> and <i>StationWare</i> for bidirectional settings transfer.....	8
<b>3 Reference Material</b> .....	<b>9</b>
<b>4 Disclaimer</b> .....	<b>10</b>

## 1 Introduction

This is the accompanying documentation for the *DigSILENT Pacific* model of the GEC Alstom GEC-CDG66-AML23FF608G.

The type CDG 11 relay is a heavily damped induction disc unit with an inverse definite minimum time/current characteristic. The relay gives selective phase and earth fault overcurrent protection in time graded systems to transformers, ac machines and feeders and ensures that a minimum number of circuit breakers in tripped to clear a faulted section. (ALSTOM, 1998)

The CDG66 is a variant of the CDG 11 arrangement with triple pole, incorporating three time overcurrent, three instantaneous overcurrent units and two normally open electrically isolated contacts.



- The Measurement Block
- This block measures the fundamental component of currents drawn from the three phase CT, with a secondary rating 5A.
- Time Overcurrent Block

The Time Overcurrent block contains a discrete current setting range of 0.5-2 in steps of 0.25A and a continuous time dial setting of 0.1-1. The Inverse-3s No. S77398206.017 CDG11 curve is shown with below figure.

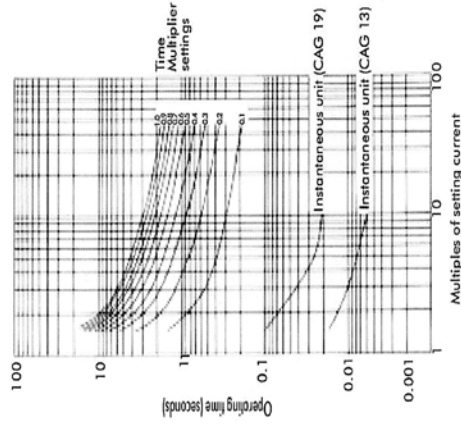

Figure 2 Time-current characteristic, inverse time relay CDG 11, 3s (ALSTOM, 1998)

- Instantaneous Overcurrent Block
- The Time Overcurrent block contains a discrete current setting range from 4-infinity in steps of 1A. The instantaneous overcurrent unit could become out of service with infinite current setting.

GEC-CDG66-AML23FF608G  
Case 1/19/1 (5)



## 2 Protection Relay

### 2.1 PowerFactory Protection Functionality

The graphic below is the GEC-CDG66/EGSCF PowerFactory Frame. The Frame shows the blocks used in the PowerFactory model.

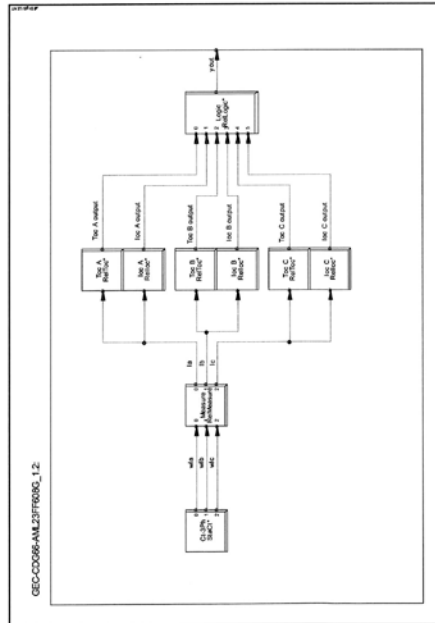

Figure 1. GEC-CDG66-AML23FF608G Frame

Each of the blocks modelled in the PowerFactory Frame (see Figure 1) represents one function of the circuit breaker, as follows:

- The CT block allows the user to select the CT ratio.

GEC-CDG66-AML23FF608G  
Case 1/19/1 (5)



- Logic Block – Trip Logic

All of the outputs from the overcurrent blocks feed into logic block. The logic block output will open the selected switch/s on fault.

### 2.2 StationWare Settings Template

Table 1 displays the StationWare Settings Template.

Table 1 StationWare Group Settings Template

Attribute	Description	Value	Range	Unit
<b>Settings</b>				
Frequency	AC Line Frequency	50	50:60	Hz
DMT	Inverse Characteristic CDG	Inverse-3s		
	11.3s			
<b>CDG66 Settings</b>				
CS A	Current Settings CDG61 Phase A	0.5	0.5-2.0:25	A
CS B	Current Settings CDG61 Phase B	0.5	0.5-2.0:25	A
CS C	Current Settings CDG61 Phase C	0.5	0.5-2.0:25	A
TMS A	Time Setting Phase A	0.15	0-1:0.01	S
TMS B	Time Setting Phase B	0.15	0-1:0.01	S
TMS C	Time Setting Phase C	0.15	0-1:0.01	S
<b>CAG13 Settings</b>				
CSCAG A	Instantaneous Current Settings CAG 13 Phase A	4	4-16:1;infinity=100000	A
CSCAG B	Instantaneous Current Settings CAG 13 Phase B	4	4-16:1;infinity=100000	A
CSCAG C	Instantaneous Current Settings CAG 13 Phase C	4	4-16:1;infinity=100000	A

CDG66 Settings  
Page 1 of 1

### 2.3 Interface between PowerFactory and StationWare for bidirectional settings transfer

Table 2 below details the bidirectional link between StationWare and PowerFactory parameters.

Table 2 StationWare/PowerFactory bidirectional link

STATIONWARE FIELDS Settings Group	Attribute	Bi-Directional Link	POWERFACTORY PARAMETERS Slot	Parameter
<b>Time Overcurrent</b>				
	CS_A	<----->	Toc A	Ipsetr
	TMS_A	<----->	Toc A	Tpsetr
	CS_B	<----->	Toc B	Ipsetr
	TMS_B	<----->	Toc B	Tpsetr
	CS_C	<----->	Toc C	Ipsetr
	TMS_C	<----->	Toc C	Tpsetr
<b>Instantaneous</b>				
	CSCAG_A	<----->	IocA	Ipsetr
	CSCAG_B	<----->	IocB	Ipsetr
	CSCAG_C	<----->	IocC	Ipsetr
	CSCAG_A	<----->	IocA	outserv
	CSCAG_B	<----->	IocB	outserv
	CSCAG_C	<----->	IocC	outserv

CDG66 Settings  
Page 1 of 1